



June 15, 2020

The Good News from Trinity PC

Onsite Trinity Worship Services

Trinity is now worshipping on Sundays in the sanctuary.

Session understands that not everyone will be comfortable returning to the building for worship. Therefore, we continue to offer recordings of the worship services.

We also have the capability to provide a video recording of the worship service, that will be live streamed at 10:15 AM or played later at your convenience. (see page 3 for details)

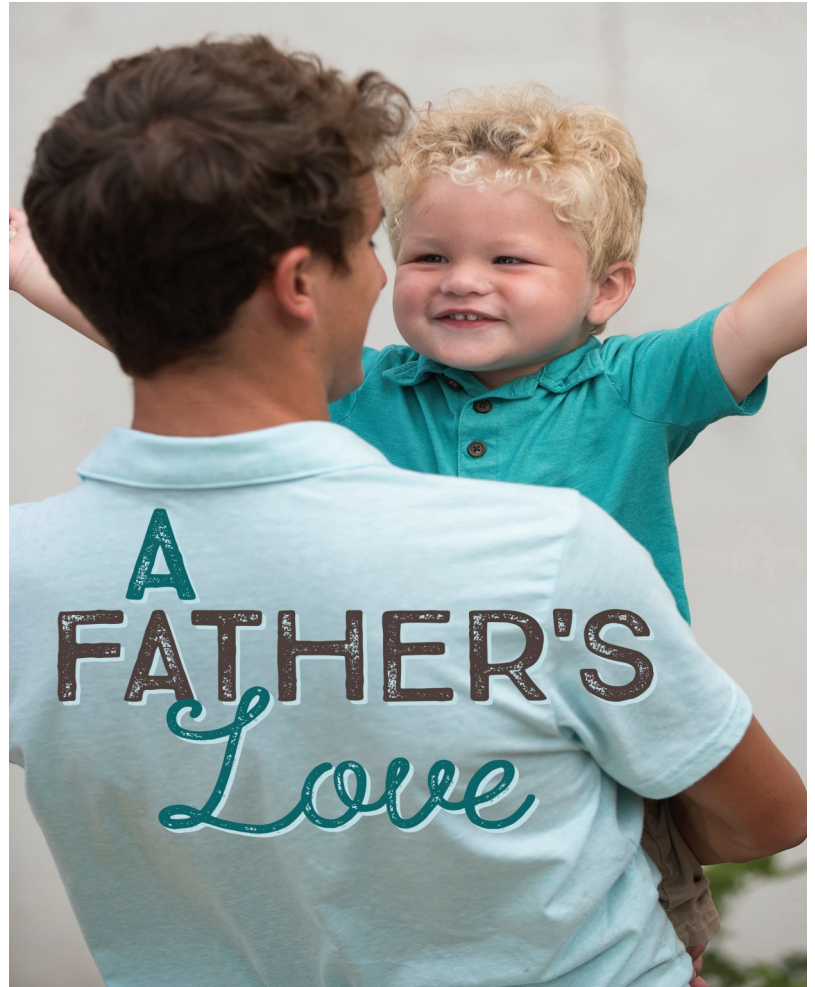

Happy Father's Day!
June 21, 2020

Office Open

9:00-Noon Monday-Thursday

Prayer Requests can be emailed to:

office@trinitypresbyfairfield.org



Trinity

Presbyterian Church
Rev. Tom Dunlap Pastor

6081 Ross Road
Corner of Ross and Mack Roads
Fairfield, Ohio 45014

Phone: 513-860-4114
www.trinitypresbyfairfield.org E-mail:
office@trinitypresbyfairfield.org

Prepare for Worship 3rd Sunday after Pentecost

Matthew 10:24-39

“A disciple is not above the teacher, nor a slave above the master; it is enough for the disciple to be like the teacher, and the slave like the master. If they have called the master of the house Beelzebul, how much more will they malign those of his household! ‘So have no fear of them; for nothing is covered up that will not be uncovered, and nothing secret that will not become known. What I say to you in the dark, tell in the light; and what you hear whispered, proclaim from the housetops. Do not fear those who kill the body but cannot kill the soul; rather fear him who can destroy both soul and body in hell. Are not two sparrows sold for a penny? Yet not one of them will fall to the ground apart from your Father. And even the hairs of your head are all counted. So do not be afraid; you are of more value than many sparrows. Everyone therefore who acknowledges me before others, I also will acknowledge before my Father in heaven; but whoever denies me before others, I also will deny before my Father in heaven. Do not think that I have come to bring peace to the earth; I have not come to bring peace, but a sword.’ For I have come to set a man against his father, and a daughter against her mother, and a daughter-in-law against her mother-in-law; and one’s foes will be members of one’s own household. Whoever loves father or mother more than me is not worthy of me; and whoever loves son or daughter more than me is not worthy of me; and whoever does not take up the cross and follow me is not worthy of me. Those who find their life will lose it, and those who lose their life for my sake will find it.’”

Reflection

When God is first in our life and our love, we serve our family and friends as God intended. How do you keep God as first love in your life?

Morning Prayer

O God, I praise you as I arise this morning. You are the giver of all life and you provide for what you have made. Move me to be generous with others, sharing not only goods, but also time, patience, and kindness. You know what will happen today. Guide me so that I do what pleases you. Be near to me and help me to trust your love. I pray for all the world today, in the name of Jesus Christ. Amen.

—adapted from *Feasting on the Word Worship Companion: Liturgies for Year A, Volume 1* © 2013 Westminster John Knox Press



June Celebrations

June Birthdays

Marta Mojzer	June 2
Majoren Tetteh (Yeboah)	June 3
Glenn Mojzer	June 13
Allison Schuler	June 13
Joleen Goens	June 15

June Anniversaries

Edna and Ron Campbell	June 19
Judy and Vernon Huber	June 26

Early July Birthdays

Edna Campbell	July 3
---------------	--------

Early July Anniversaries

Keith and Pam Harring	July 11
-----------------------	---------

***Spring being a tough act to follow,
God invented June.—Al Bernstein***

Sermons Online and on YouTube

For those that do not attend in person, Trinity will be offering on-line services live streaming at 10:15 on YouTube. To watch the video live, click on the link below which will direct you to the Trinity YouTube channel, and then click on the video in the displayed list with the **LIVE** box illuminated. We strongly encourage you to click the "subscribe" link on that page.

<https://www.youtube.com/channel/UCn4Bfx9UtjiaWsrXObnly6g>

On Sunday afternoon, the recorded live service will also be available via link through the Trinity website at the link below:

<https://www.trinitypresbyfairfield.org/sermons/>

Sandwiches for the Homeless Thank You!

We thank everyone who made sandwiches for our *Daily Bread*, a food pantry for the homeless. Our goal was to contribute 300 sandwiches and 347 sandwiches were prepared and donated. This was our response to a challenge from the Presbytery to help serve the ever growing need for food for the homeless community.

We appreciate your generous contributions to help reach out to others in this difficult time!



Installation and Ordination This Sunday

Sunday, we will be installing Elders Kurt Schuler and Barb Pratt. Wilson Tayong is being both ordained and installed as an Elder. Ginny Kramer will be installed as a Deacon and Valentine Nyamusa is being ordained and installed as a Deacon.

We thank Cindie Postell and Allison Schuler our retiring officers and all of our present and former officers for their dedication to serving the Trinity family.

We are grateful for our Elders and Deacons! Please keep them and all our officers in your prayers.

Bulletins on Thursday

On Thursdays, you will receive a bulletin via email for the Sunday service. Davis will be playing the hymns in the video service on the web page. Lyrics will be included in your bulletin. Please check your emails on Thursday and be prepared to sing along on Sunday. If you are planning on attending

From the Treasurer:

Please continue to mail in your pledges even though we are not physically attending services. The general costs to operate the church still continue. Your donations are being processed and deposited each week. Thank you for keeping your pledges up to date.

Father's Day Thoughts

A Houston newspaper asked readers to send in thoughts about their fathers. Letters flooded in, and what people wrote about their fathers is most inspiring.

A few comments:

- Dad was always there for me. He sacrificed to make sure that we had what we needed.
- When disappointment came my way, Dad said, "Son, real life ain't about getting what you want but more about doing something with what you get."
- My dad was disabled, but he worked hard to make sure we children had a good education and lived moral lives. He would say, "I want you to succeed more than I did."

Onsite Worship Protocols

Trinity has begun Onsite Worship. Below are the preparations and changes to the worship service that have been made:

Preparations for the Trinity building include:

- Thoroughly cleaning on a regular basis, with frequently touched surfaces being sanitized.
- Church front entry doors, as well as the middle and side entry doors to the sanctuary, are propped open and will remain open for the entire worship service. (minimizes contact with the door handles and increases ventilation within the church building.
- Bottles of liquid hand sanitizer will be available for use in the narthex, and you are encouraged as well to bring your own personal hand sanitizer. The water fountains outside the restrooms will be unplugged and covered on Sunday morning. Please bring your own personal water containers or bottles. No food or beverages will be offered. The sacristy room will be closed.
- When utilizing the restroom on Sunday morning, note whether another person is already using the room, and wait outside until that person exits the restroom before entering. Wash your hands thoroughly with soap and water prior to exiting the restroom.
- While inside the church building, **we are strongly encouraging that each person wear a face covering or mask.** A limited number of surgical masks will be available if you forget your own personal face covering.
- If on Sunday morning you are experiencing a fever (in excess of 100.4° F), coughing, shortness of breath or other symptoms potentially indicating COVID-19 infection, please refrain from attending worship on that morning and seek medical assistance.

The worship service itself will, not surprisingly, be a little different than what we are accustomed to. Some of the worship service modifications will be:

- We anticipate that attendance at the initial services will be quite modest, so the ushers should easily be able to assist individuals and family groups to find seating in the pews with appropriate social distancing.
- No printed bulletins will be distributed by the ushers. Everyone will receive an electronic version of each week's bulletin by email, and you are encouraged to print out the bulletin at home and bring it with you on Sunday morning. A limited number of printed bulletins will be available in the narthex. The bulletin will include the hymn lyrics.
- Hymnbooks, Bibles, pencils and attendance pads will be removed. Prayer request forms will be displayed on a table in the narthex, that can be filled out prior to the service, which can then be deposited in offering baskets located at the sanctuary entry doors.
- There will be no choir performances, and congregational singing of the hymns will be discouraged. Singing of the hymns in our minds, or possibly light humming, will be our means of expressing our musical worship.
- There will be no children's sermon or children's Sunday school classes, so children will remain with their families during worship. **No nursery attendants will be provided**, so use of the nursery room will be limited to parents and their children, if necessary.
- There will be no collection of offering during the service. Offerings will be deposited in the offering baskets located at the sanctuary entry doors when departing the sanctuary at the conclusion of the service.
- On Communion Sundays (first Sunday of the month) servers will not be distributing the communion elements. Trinity has purchased a supply of prepackaged communion "sets", each with a wafer and sealed juice cup, which will be placed on a table at the front of the sanctuary, to be picked up by individual worshippers at the appointed time during the communion service.
- Following Rev. Dunlap's benediction, he, or the preacher of the day, will immediately proceed outside the church building, to greet and chat with the worshippers in the safer, fresher outdoor environ (no rain please!). All of the attendees will be encouraged to proceed to the outside as quickly as possible. It's outside, in the fresh air, that we can really practice being the Trinity community of faith - socially distanced hugs, catching up on all our quarantine stories, etc.!

Trust in Christ

Scripture: Psalm 66:8–20

Tested

*For you, O God, have tested us;
you have tried us as silver is tried.*

Psalm 66:10

M. Scott Peck began his best-selling book, *The Road Less Traveled*, with these words: “Life is difficult. This is the great truth, one of the greatest truths. It is a great truth because once we truly see this truth, we transcend it.”* The psalmist says much the same thing, though it is in the context of his abiding trust in God. He acknowledges the difficulties that every life encounters. To be “tested” is to be tried “like silver.”

To accept that life is not easy for anyone, never free of “tests,” is the first step in living through inevitable life challenges. The next step, which the psalmist describes later, is to trust that God will be with us and strengthen us through life’s difficulties. God will bring “us out to a spacious place” (v. 12) where our trials are behind us.

Loving God, we know that life can be difficult. Be with us and strengthen us so that we may come once again to “a spacious place.” Amen.

Michael L. Lindvall, Fort Wayne, Indiana

*M. Scott Peck, *The Road Less Traveled* (New York: Simon and Schuster, 1979), 1.

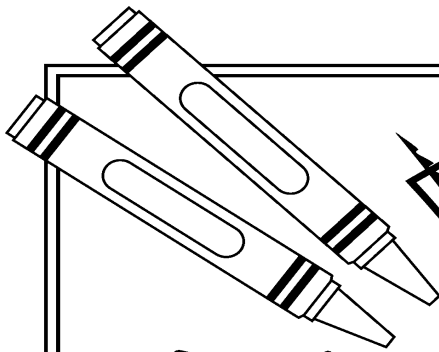

PUZZLE

Beloved children

God our heavenly Father loves us so much that he calls us his.

Directions: Follow the instructions below. Then read the remaining words, going across the rows from left to right, to complete 2 Corinthians 6:18, NIV.

- Cross out the opposite of blessings.
- Cross out the disciple who betrayed Jesus.
- Cross out the opposite of love.
- Cross out a word for jail.
- Cross out what happened to Jesus.
- Cross out the opposite of friends.
- Cross out the opposite of found.
- Cross out a word for disobeying God.
- Cross out an animal.
- Cross out a place.
- Cross out a book of the Bible.

I	enemies	will	be	Judas
hate	a	Father	to	serpent
you	and	you	will	crucified
cursings	be	my	sons	and
sin	Golgotha	daughters	says	the
Lamentations	prison	Lord	Almighty	lost

Answer: "I will be a Father to you, and you will be my sons and daughters, says the Lord Almighty." 2 Corinthians 6:18, NIV

Children's Worship Bulletin™

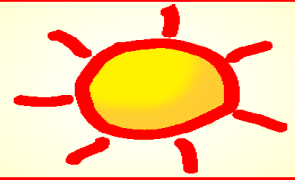

Ages 3+

March 24, 2019 • 1 Samuel 20:1-42

Jonathan sent a secret message to David.
Jonathan shot arrows far beyond David.
Then David knew he must flee.

Connect the dots.
1 2 3 4 5 6 7 8 9 10 11 12

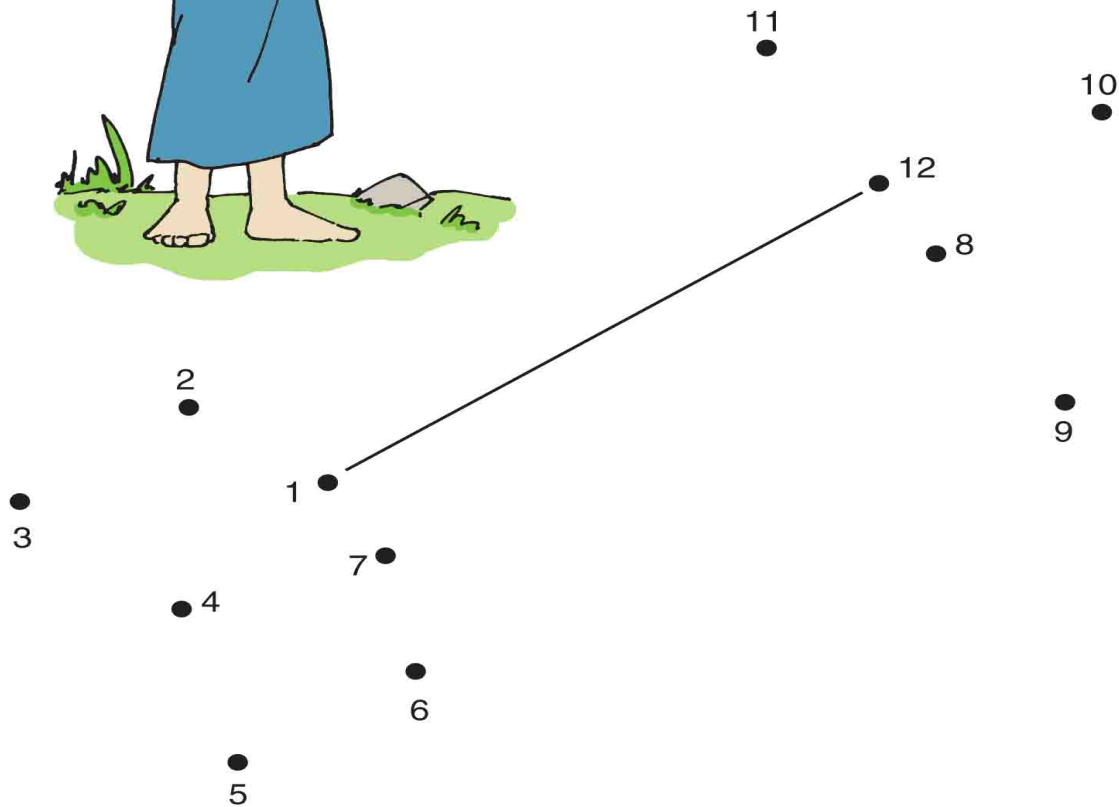

• Children's Worship Bulletin™ •

Ages 7+

March 24, 2019 • 1 Samuel

What did Jonathan tell David?



Use the code to decipher what the secret sign was.

A	B	C	D	E	F	G	H	I	J	K	L	M	N	O	P	Q	R	S	T	U	V	W	X	Y	Z
1	2	3	4	5	6	7	8	9	10	11	12	13	14	15	16	17	18	19	20	21	22	23	24	25	26

“Wait by a stone in the field. 9 23 9 12 12

19 8 15 15 20 20 8 18 5 5

1 18 18 15 23 19. Then I will send a boy

and say, ‘7 15, 6 9 14 4 20 8 5

1 18 18 15 23 19.’ If I say to him,

‘12 15 15 11, 20 8 5

1 18 18 15 23 19 1 18 5

15 14 20 8 9 19 19 9 4 5

15 6 25 15 21; 2 18 9 14 7

20 8 5 13 8 5 18 5, then you are

safe; there is no danger. But if I say to the boy,

‘12 15 15 11, 20 8 5

1 18 18 15 23 19 1 18 5

2 5 25 15 14 4 25 15 21, then you

must go, because the Lord has sent you away.”

THE GOOD NEWS

As of June 14

Keep in your Prayers

Debbie Jonson	Healing/knee surgery
Bob Miller, D. Schuler request	Healing/heart concerns
Steve, Kathy Kessler's son	Thanksgiving successful surgery/hip replacement
Family of Nancy Chamberlain, Schuler's request	Bereavement/loss of Nancy
Family of Chet Hard, Schuler request	Bereavement/loss of Chet
Madison, Cindie Postell's granddaughter	Thanksgiving/home/2 months of rehabilitation
Mike, Marta Mojzer's brother	Healing/advanced liver failure and other concerns
*All families in distress/difficulties with COVID	God's support/strength, guidance
Gina Anaple	Healing/recovering surgery
Fran Thomas	Healing/pain relief
Natasha, B. Pratt request	Healing/recovery surgery on legs
Jean Parsley	Continued healing
Pam Harring	Continued healing/guidance with treatment
George Liles	Continued healing/home recovering
Dee Burkhardt	Continued healing
Diane Niehaus, B. Luebbe request	Continued healing/several health concerns
Gerald Reese, M. Reese's father	Continued healing/swallowing problems
Margie, Fran Thomas' sister	God's peace and comfort
All peoples in the Middle East	Peace and reconciliation
All Elected Government leaders	Wisdom/support/enlightenment
Support for all our military	Strength/discernment/God's protection
For all missionaries (Especially for S. and B.)	Protection/blessings/fruitful mission work

Names that have been on the Prayer List for more than 4 weeks are marked with an asterisk ().
If you would like them to remain on the list, please contact the office by Tuesday.*

Financial Information

Donations Received as of 6/14	\$1,710
Pentecost Offering	\$85
Per Capita 2020 Donations	\$825
Property Fund Giving 2020	\$3,500
Property Fund Goal 2020	\$5,000

Per Capita for 2020 is \$33

Worship Schedule

June 14	Elder Kurt Schuler
June 21	Rev. Tom Dunlap
June 28	Elder George Fraley
July 5	Rev. Tom Dunlap