



**June 1, 2020**

## **The Good News from Trinity PC**

### **Onsite Trinity Worship Services For June 7**

Please **RSVP by email to the office** ([office@trinitypresbyfairfield.org](mailto:office@trinitypresbyfairfield.org)) or call 513-860-4114 to RSVP by June 4 if you are planning to begin attending again.

We hope to get a count of those who will be attending to plan the safe distancing within the sanctuary. (Please see page 4 for details.)

Session understands that not everyone will be comfortable returning to the building for worship. Therefore, we will continue to offer recordings of the worship service.

We also have the capability to provide a video recording of the worship service, that will be live streamed at 10:15 AM or played later at your convenience. (please see page 3 )

**This Sunday we will receive the Pentecost Offering as we celebrate Pentecost.**

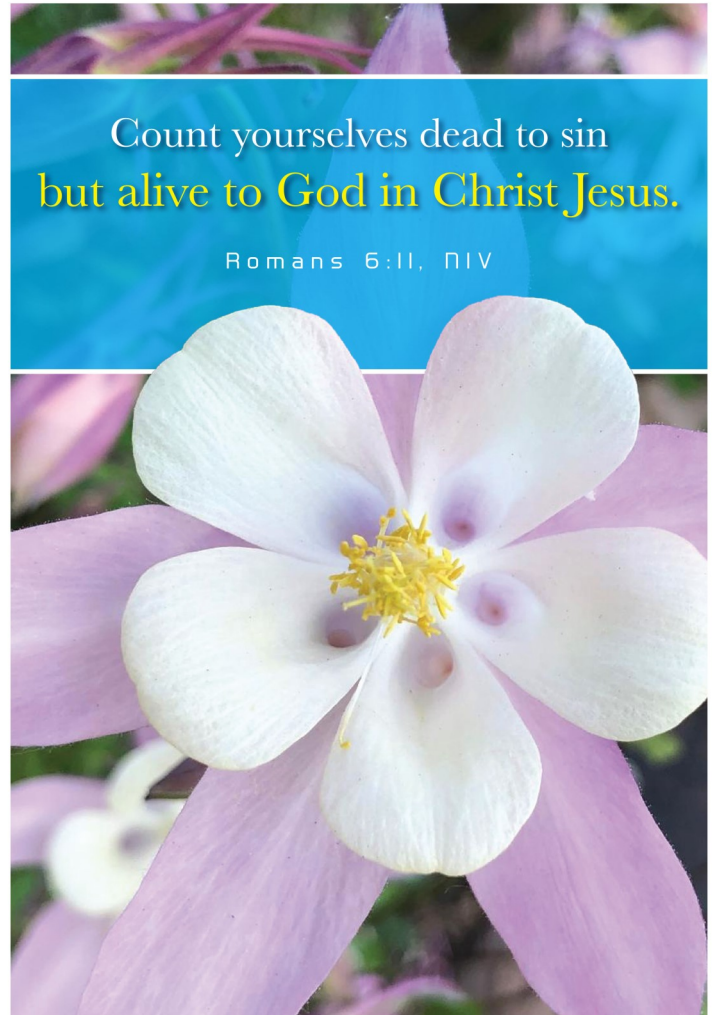

#### **Office Open**

**9:00-Noon Monday-Thursday**

**Prayer Requests can be emailed to:  
[office@trinitypresbyfairfield.org](mailto:office@trinitypresbyfairfield.org)**



**Trinity Presbyterian Church**

Rev. Tom Dunlap Pastor

6081 Ross Road  
Corner of Ross and Mack Roads  
Fairfield, Ohio 45014

Phone: 513-860-4114  
[www.trinitypresbyfairfield.org](http://www.trinitypresbyfairfield.org) E-mail:  
[office@trinitypresbyfairfield.org](mailto:office@trinitypresbyfairfield.org)

Prepare for Worship  
Pentecost

**Acts 2:1-21**

“When the day of Pentecost had come, they were all together in one place. And suddenly from heaven there came a sound like the rush of a violent wind, and it filled the entire house where they were sitting. Divided tongues, as of fire, appeared among them, and a tongue rested on each of them. All of them were filled with the Holy Spirit and began to speak in other languages, as the Spirit gave them ability. Now there were devout Jews from every nation under heaven living in Jerusalem. And at this sound the crowd gathered and was bewildered, because each one heard them speaking in the native language of each. Amazed and astonished, they asked, ‘Are not all these who are speaking Galileans? And how is it that we hear, each of us, in our own native language? Parthians, Medes, Elamites, and residents of Mesopotamia, Judea and Cappadocia, Pontus and Asia, Phrygia and Pamphylia, Egypt and the parts of Libya belonging to Cyrene, and visitors from Rome, both Jews and proselytes, Cretans and Arabs—in our own languages we hear them speaking about God’s deeds of power.’ All were amazed and perplexed, saying to one another, “What does this mean?” But others sneered and said, ‘They are filled with new wine.’ But Peter, standing with the eleven, raised his voice and addressed them, ‘Men of Judea and all who live in Jerusalem, let this be known to you, and listen to what I say. Indeed, these are not drunk, as you suppose, for it is only nine o’clock in the morning. No, this is what was spoken through the prophet Joel’:

‘In the last days it will be, God declares, that I will pour out my Spirit upon all flesh, and your sons and your daughters shall prophesy, and your young men shall see visions, and your old men shall dream dreams. Even upon my slaves, both men and women, in those days I will pour out my Spirit; and they shall prophesy. And I will show portents in the heaven above and signs on the earth below, blood, and fire, and smoky mist. The sun shall be turned to darkness and the moon to blood, before the coming of the Lord’s great and glorious day. Then everyone who calls on the name of the Lord shall be saved.’”

**Reflection**

How have you received “grace upon grace” in your life through Jesus Christ? Can you think of times when God has turned your mourning into joy, your sorrow into gladness? Does the incarnation of Christ call us to “make flesh” the love of God for others?

**Morning Prayer**—God who gives birth to the new heaven and the new earth, midwife in me your love made flesh for others as I live in your world today. Amen.

—adapted from *Feasting on the Word Worship Companion: Liturgies for Year A, Volume 1* © 2013 Westminster John Knox Press

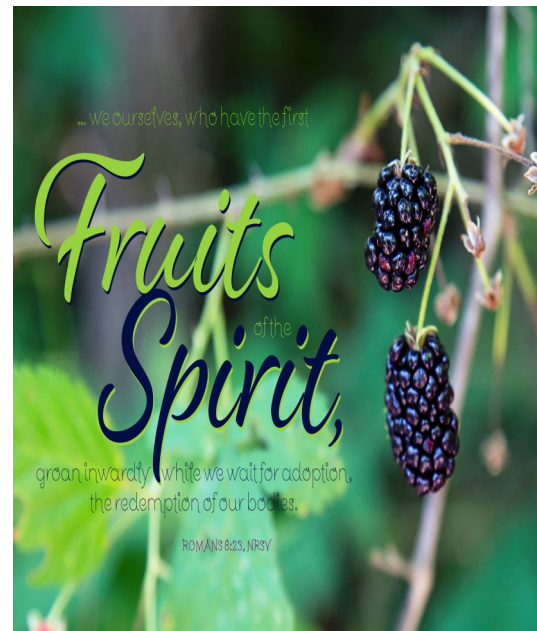

**The Wine of the Spirit**

“No one puts new wine into old wineskins,” said Jesus (Luke 5:37). Drawing on this statement, a preacher in sixth-century Africa proclaimed in a Pentecost homily:

“It was with good reason, then, that some people, when they heard the apostles speaking in every tongue, said, ‘They are filled with the new wine.’ For they had become fresh wineskins, they had been renewed by the grace of holiness, so that when they were filled with the new wine, that is, with the Holy Spirit, they spoke with fervor in every tongue. ...

“Celebrate, then, this day as members of the one body of Christ. Your celebration will not be in vain if you are what you celebrate, if you hold fast to the church which the Lord filled with his Holy Spirit.”

Fifteen centuries later, may that call still resonate with us. May we be so renewed by God’s grace as to be worthy vessels of the new wine of the Holy Spirit – and to share it with the world.

## Sermons Online and on YouTube

For those that do not attend in person, Trinity will be offering on-line services live streaming at 10:15 on YouTube. To watch the video live, click on the link below which will direct you to the Trinity YouTube channel, and then click on the video in the displayed list with the LIVE box illuminated. We strongly encourage you to click the "subscribe" link on that page.

<https://www.youtube.com/channel/UCn4Bfx9UtjiaWsrXObnly6g>

On Sunday afternoon, the recorded live service will also be available via link through the Trinity website at the link below:

<https://www.trinitypresbyfairfield.org/sermons/>

## Sandwiches for the Homeless

We will once again be **making sandwiches on June 11**. Trinity signed up to make 300 sandwiches. The mission committee will provide the packages of mayo/mustard to add to the sandwiches. Please note the instructions for making the sandwiches:

- *place sandwiches in zipper sandwich baggies and label with type of sandwich.*
- *Meat Sandwiches: We usually only put bread, meat and packaged mayo/mustard in each baggie. If you can provide cheese and/or lettuce on the sandwich that is a bonus, but we don't put on anything that will make the bread soggy. Any type of bread or meat is accepted, but our guests tend to prefer white bread over wheat and turkey, pepperoni, and bologna over other meats like ham or roast beef.*
- *PB&J Sandwiches: No rules really except making sure not to overload the bread with jam/jelly so the bread doesn't get too soggy.*

**We appreciate your help in reaching out to meet the growing need of the homeless at food banks.**

## Bulletins on Thursday

On Thursdays, you will receive a bulletin via email for the Sunday service. Davis will be playing the hymns in the video service on the web page. Lyrics will be included in your bulletin. Please check your emails on Thursday and be prepared to sing along on Sunday. If you are planning on attending

## Preparing for the Future

If anyone in the congregation needs a mask for when you return to worship, please email the office at: [office@trinitypresbyfairfield.org](mailto:office@trinitypresbyfairfield.org) or call 513-860-4114. We have volunteers who are willing to make a mask for you.

## From the Treasurer:

Please continue to mail in your pledges even though we are not physically attending services. The general costs to operate the church still continue. Your donations are being processed and deposited each week. Thank you for keeping your pledges up to date.

## Missions at Work

- ♦ Sewing dresses while at home for Mission Project in Appalachia.
- ♦ Knitters /Crocheters: Mercy and our church are in need of prayer shawls and baby blankets.
- ♦ Collecting plastic lids, soda pull tabs, and cancelled stamps

# Onsite Worship for June 7

We ask you to **RSVP by email to the office ([office@trinitypresbyfairfield.org](mailto:office@trinitypresbyfairfield.org)) or call 513-860-4114 to RSVP by June 4 if you are planning to attend.** We hope to get a count of those who will be attending to plan the safe distancing within the sanctuary.

## Preparations for the Trinity building include:

- Thoroughly cleaning on a regular basis, with frequently touched surfaces being sanitized.
- Church front entry doors, as well as the middle and side entry doors to the sanctuary, are propped open and will remain open for the entire worship service. (minimizes contact with the door handles and increases ventilation within the church building.)
- Bottles of liquid hand sanitizer will be available for use in the narthex, and you are encouraged as well to bring your own personal hand sanitizer. The water fountains outside the restrooms will be unplugged and covered on Sunday morning. Please bring your own personal water containers or bottles. No food or beverages will be offered. The sacristy room will be closed.
- When utilizing the restroom on Sunday morning, note whether another person is already using the room, and wait outside until that person exits the restroom before entering. Wash your hands thoroughly with soap and water prior to exiting the restroom.
- While inside the church building, **we are strongly encouraging that each person wear a face covering or mask.** A limited number of surgical masks will be available if you forget your own personal face covering.
- If on Sunday morning you are experiencing a fever (in excess of 100.4° F), coughing, shortness of breath or other symptoms potentially indicating COVID-19 infection, please refrain from attending worship on that morning and seek medical assistance.

## The worship service itself will, not surprisingly, be a little different than what we are accustomed to. Some of the worship service modifications will be:

- We anticipate that attendance at the initial services will be quite modest, so the ushers should easily be able to assist individuals and family groups to find seating in the pews with appropriate social distancing.
- No printed bulletins will be distributed by the ushers. Everyone will receive an electronic version of each week's bulletin by email, and you are encouraged to print out the bulletin at home and bring it with you on Sunday morning. A limited number of printed bulletins will be available in the narthex. The bulletin will include the hymn lyrics.
- Hymnbooks, Bibles, pencils and attendance pads will be removed. Prayer request forms will be displayed on a table in the narthex, that can be filled out prior to the service, which can then be deposited in offering baskets located at the sanctuary entry doors.
- There will be no choir performances, and congregational singing of the hymns will be discouraged. Singing of the hymns in our minds, or possibly light humming, will be our means of expressing our musical worship.
- There will be no children's sermon or children's Sunday school classes, so children will remain with their families during worship. **No nursery attendants will be provided**, so use of the nursery room will be limited to parents and their children, if necessary.
- There will be no collection of offering during the service. Offerings will be deposited in the offering baskets located at the sanctuary entry doors when departing the sanctuary at the conclusion of the service.
- On Communion Sundays (e.g., June 7) servers will not be distributing the communion elements. Trinity has purchased a supply of prepackaged communion "sets", each with wafer and sealed juice cup, which will be placed on a table at the front of the sanctuary, to be picked up by individual worshippers at the appointed time during the communion service.
- Following Rev. Dunlap's benediction, he, or the preacher of the day, will immediately proceed outside the church building, to greet and chat with the worshippers in the safer, fresher outdoor environ (no rain please!). All of the attendees will be encouraged to proceed to the outside as quickly as possible. It's outside, in the fresh air, that we can really practice being the Trinity community of faith - socially distanced hugs, catching up on all our quarantine stories, etc.!



# New Prayer Wall

Trinity has an exciting new capability through the website that allows anyone to post needed prayers on what we've called the "Prayer Wall". From the website home page, you may click on the Prayer Request image or click on the link:

<https://www.trinitypresbyfairfield.org/prayer-wall/>.

From there you may click on the button "Share your prayer request". Enter the information on the box that appears. You have the option to select whether you want the prayer: Shared online; Online but Anonymous; or Not shared online at all (in that case, the prayer is only sent to the church office and added to the traditional prayer list). You may also select the check box that will Email you when someone prays for your request. When you're finished making your selections, click the "I'm not a robot" box, and hit the submit button. That's it! We hope this new website feature is a blessing to Trinity.

Here is what the Prayer Wall looks like:

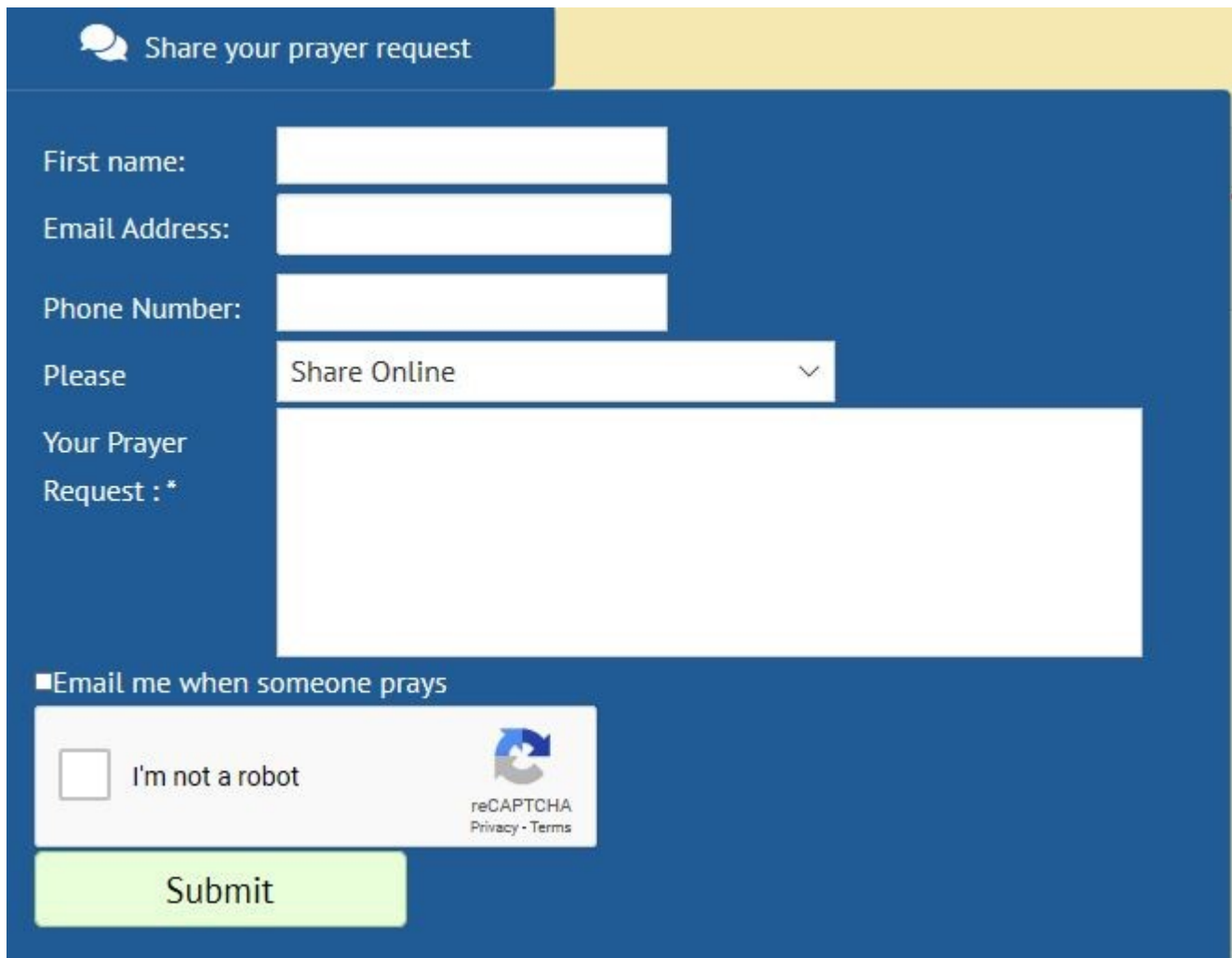

The screenshot shows a web form titled "Share your prayer request" on a blue background. The form includes the following fields and elements:

- First name:** A white text input field.
- Email Address:** A white text input field.
- Phone Number:** A white text input field.
- Please:** A dropdown menu with "Share Online" selected and a downward arrow.
- Your Prayer Request : \*** A large white text area for entering the prayer request.
- Email me when someone prays**
- I'm not a robot** (reCAPTCHA widget)
- reCAPTCHA logo and text: "reCAPTCHA Privacy - Terms"
- Submit** button (green)

# New Life in Christ

## Scripture: Acts 7:55–60

### Spirit Power

*But filled with the Holy Spirit, he gazed into heaven and saw the glory of God and Jesus standing at the right hand of God.*

Acts 7:55

When Stephen faced a crowd angered by his declaration of faith in Jesus, he did not cease his witness. Empowered by the Holy Spirit, he looked to God and continued his brave proclamation of faith. Stephen did not do this on his own but by the power of God's presence with him.

A seminary professor of mine once defined the Holy Spirit as "the present tense of God." Time and again in my life and ministry, I have felt unequal to some task before me. Maybe I was staring at a computer screen struggling with a sermon or preparing to attend a challenging committee meeting.

At times like this, I have found myself driven to pray for God's strengthening and empowering presence—the Holy Spirit—to do what I was called to do. Like Stephen, all of us often find ourselves "unequal to the task before us." The promise is that we are not alone but that "God in the present tense" can empower us to do what we cannot do on our own.

*Come, Holy Spirit, and enable us to do what we cannot do alone. Amen.*

# COLORING PAGE



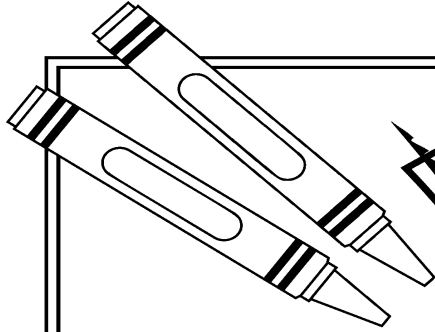

# PUZZLE

## Transformation **POWER**



Just as the caterpillar becomes a butterfly,  
God transforms us from old to new.



*Directions: Cross out the backward letters. Write the remaining letters in order in the spaces below to complete 2 Corinthians 5:17, NIV.*

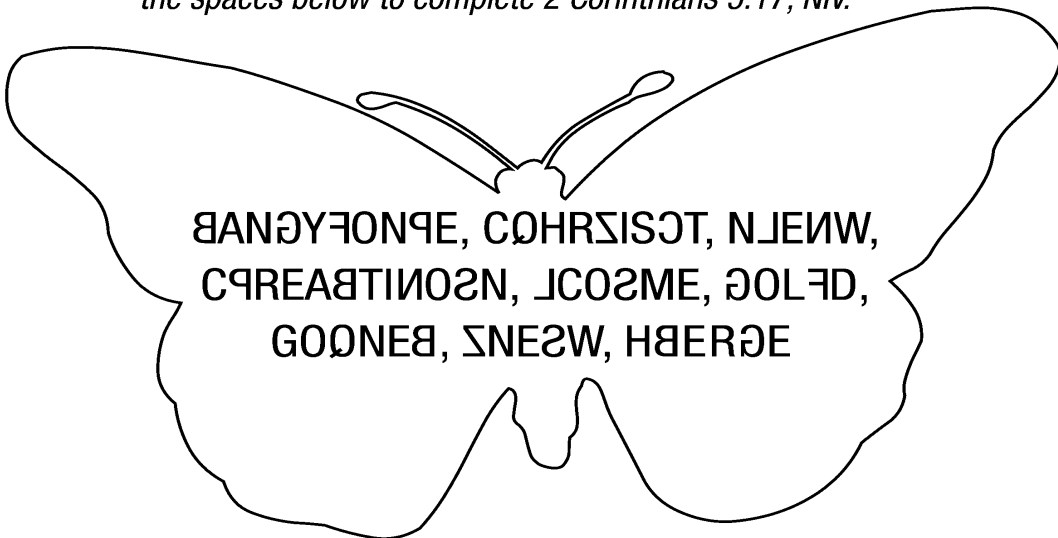

Therefore, if \_\_\_\_\_ is in \_\_\_\_\_,

the \_\_\_\_\_ has \_\_\_\_\_:

The \_\_\_\_\_ has \_\_\_\_\_,

the \_\_\_\_\_ is \_\_\_\_\_!

2 C O R I N T H I A N S 5 : 1 7 , N I V

Answer: anyone, Christ, new, creation, come, old, gone, new, here



# Children's Worship Bulletin™

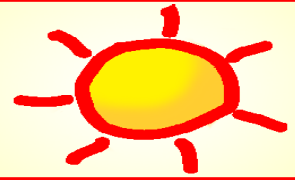

Ages 3+

June 9, 2019 • Acts 2:1-21

It looked like tongues of fire  
came to rest on them.

Count the flames of fire. Trace the numbers.

A grid of 12 cartoon figures of men with beards and head coverings, each with a flame above their head. The flames are numbered 1 through 12. The numbers 1, 2, 3, 4, 5, 6, 7, 8, 9, 10, 11, and 12 are shown as dashed lines for tracing. The figures are colored in various ways: some are black and white, some have colored clothing (red, blue, green, yellow, purple), and some have colored head coverings (blue, green, orange).



As of May 31

## Keep in your Prayers

Nancy Chamberlin, Donna Schuler req.	Peace and comfort/gravely ill; unresponsive
Mike, Marta Mojzer's brother	Healing/advanced liver failure and other concerns
All families in distress/difficulties with COVID	God's support/strength, guidance
Gina Anaple	Healing/recovery surgery
Laverne Mitchell, Connie Williams req.	Healing/diagnosed advanced cancer
Chris Clark, Marta Mojzer's cousin	Healing/cancer has returned
*Sandy Thien, Ginny Kramer's niece	Healing/cancer/chemo treatments
*Pam Kelso, Carol Kiphart's daughter	Healing/diagnosed with cancer
Fran Thomas	Healing/pain relief
Natasha, B. Pratt request	Healing/recovery surgery on legs
Jean Parsley	Continued healing
Pam Harring	Continued healing/guidance with treatment
George Liles	Continued healing/home recovering
Dee Burkhardt	Continued healing
Diane Niehaus, B. Luebbe request	Continued healing/several health concerns
Gerald Reese, M. Reese's father	Continued healing/swallowing problems
Margie, Fran Thomas' sister	God's peace and comfort
All peoples in the Middle East	Peace and reconciliation
All Elected Government leaders	Wisdom/support/enlightenment
Support for all our military	Strength/discernment/God's protection
For all missionaries (Especially for S. and B. )	Protection/blessings/fruitful mission work

*Names that have been on the Prayer List for more than 4 weeks are marked with an asterisk (\*). If you would like them to remain on the list, please contact the office by Tuesday.*

### Financial Information

Donations Received as of 5/31	\$2,642
Per Capita 2020 Donations	\$825
Property Fund Giving 2020	\$3,500
Property Fund Goal 2020	\$5,000
Per Capita for 2020 is \$33	

### Worship Schedule

June 7	Rev. Tom Dunlap
June 14	Elder Kurt Schuler
June 21	Rev. Tom Dunlap
June 28	Elder George Fraley