



May 26, 2020

The Good News from Trinity PC

Trinity Worship Services for May 31, 202

Onsite Trinity Worship Services Begins on May 31

Please **RSVP by email to the office** (office@trinitypresbyfairfield.org) or call 513-860-4114 to RSVP by May 28 if you are planning to attend.

We hope to get a count of those who will be attending to plan the safe distancing within the sanctuary. When we resume our worship we will begin by celebrating Easter. (Please see page 4 for details.)

Session understands that not everyone will be comfortable returning to the building for worship at the end of May. Therefore, we plan to continue to offer recordings of the worship service on May 31 and subsequent Sundays.

We also hope to soon have the capability to provide a video recording of the worship service, that can be live streamed at 10:15 AM or played later at your convenience.



Office Open

9:00-Noon Monday-Thursday

**Prayer Requests can be emailed to:
office@trinitypresbyfairfield.org**



Trinity Presbyterian Church

Rev. Tom Dunlap Pastor

6081 Ross Road
Corner of Ross and Mack Roads
Fairfield, Ohio 45014

Phone: 513-860-4114
www.trinitypresbyfairfield.org E-mail:
office@trinitypresbyfairfield.org

Prepare for Worship Easter Celebration

Psalm 104:24-34

“O LORD, how manifold are your works!
In wisdom you have made them all;
the earth is full of your creatures.
Yonder is the sea, great and wide,
creeping things innumerable are there,
living things both small and great.
There go the ships,
and Leviathan that you formed to sport in it.
These all look to you
to give them their food in due season;
when you give to them, they gather it up;
when you open your hand, they are filled with
good things.
When you hide your face, they are dismayed;
when you take away their breath, they die
and return to their dust.
When you send forth your spirit,^[a] they are created;
and you renew the face of the ground.
May the glory of the LORD endure forever;
may the LORD rejoice in his works—
who looks on the earth and it trembles,
who touches the mountains and they smoke.
I will sing to the LORD as long as I live;
I will sing praise to my God while I have being.
May my meditation be pleasing to him,
for I rejoice in the LORD.”

Reflection

What prophetic word for the community has God given to you? In what ways do you struggle with conflicts between your way of life and the prophetic word God would have you proclaim to others? How are the acts of God manifest in your life and witness?

Morning Prayer

Spirit of God, source of life, refresh my spirit,
reshape my desire, and re-create my heart, that
I may show forth your enduring glory; through
Jesus Christ. Amen.

—adapted from *Feasting on the Word Worship Companion: Liturgies for Year A, Volume 1* © 2013 Westminster John Knox Press



A Spirit Who Comforts

In a time when life expectancy was around 40 years, Hildegard of Bingen (1098-1179) lived more than twice that long. The Benedictine abbess and mystic wrote books and music, founded two convents, conducted four “preaching tours” and much more, despite chronic illness, lack of schooling, grave self-doubt and a male-dominated church and society. Perhaps these poetry excerpts reveal her source of strength and inspiration:

O comforting fire of Spirit,
Life, within the very Life of all Creation.
Holy you are in giving life to All. ...

O sacred breath, O fire of love ...
O most pure fountain
through whom it is known
that God has united strangers
and inquired after the lost. ...

You always draw out knowledge,
bringing joy through Wisdom's inspiration.

Therefore, praise be to you
who are the sound of praise
and the greatest prize of Life,
who are hope and richest honor
bequeathing the reward of Light.

Sermons on-line and on YouTube

Rev. Dunlap has recorded his message for this Sunday and it is on the Trinity web page at the link below. It will be posted by Saturday. This week's recording is a full service with music, including again Davis on piano. You will notice a change in the player this week on the website page as we are preparing to offer full video services in the near future.

Please see:

<http://www.trinitypresbyfairfield.org/sermon>

To play the service, click on the "video" button under the correct date heading (Company). When the current sermon page opens, you will need to click on the arrow in the center of the video screen to begin the service. You may click on the small circular icon of Trinity in the upper left of the video screen to go directly to the Trinity YouTube channel as well. As always, the current bulletin is available on the web page for download.

Also on the link is Elder George Fraley message "What Will You Request?" from May 24.

Sandwiches for the Homeless

We will once again be making sandwiches on June 11. Trinity signed up to make 300 sandwiches. The mission committee will provide the packages of mayo/mustard to add to the sandwiches. Please note the instructions for making the sandwiches:

- *place sandwiches in zipper sandwich baggies and label with type of sandwich.*
- *Meat Sandwiches: We usually only put bread, meat and packaged mayo/mustard in each baggie. If you can provide cheese and/or lettuce on the sandwich that is a bonus, but we don't put on anything that will make the bread soggy. Any type of bread or meat is accepted, but our guests tend to prefer white bread over wheat and turkey, pepperoni, and bologna over other meats like ham or roast beef.*
- *PB&J Sandwiches: No rules really except making sure not to overload the bread with jam/jelly so the bread doesn't get too soggy.*

We appreciate your help in reaching out to meet the growing need of the homeless at food banks.

Bulletins on Thursday

On Thursdays, you will receive a bulletin via email for the Sunday service. Davis will be playing the hymns in the recorded service on the web page. Lyrics will be included in your bulletin. Please check your emails on Thursday and be prepared to sing along on Sunday.

Preparing for the Future

If anyone in the congregation needs a mask for when you return to worship, please email the office at: office@trinitypresbyfairfield.org or call 513-860-4114. We have volunteers who are willing to make a mask for you.

From the Treasurer:

Please continue to mail in your pledges even though we are not physically attending services. The general costs to operate the church still continue. Your donations are being processed and deposited each week. Thank you for keeping your pledges up to date.

Missions at Work

- ♦ Sewing dresses while at home for Mission Project in Appalachia.
- ♦ Knitters /Crocheters: Mercy and our church are in need of prayer shawls and baby blankets.
- ♦ Collecting plastic lids, soda pull tabs, and cancelled stamps

"Never yet was a springtime, when the buds forgot to bloom."

—Margaret Elizabeth Sangster

Trinity is Restarting Onsite Worship on May 31

We ask you to **RSVP by email to the office (office@trinitypresbyfairfield.org) or call 513-860-4114 to RSVP by May 28 if you are planning to attend.** We hope to get a count of those who will be attending to plan the safe distancing within the sanctuary. When we resume onsite worship we will begin by celebrating Easter.

Preparations for the Trinity building include:

- Thoroughly cleaning on a regular basis, with frequently touched surfaces being sanitized.
- Church front entry doors, as well as the middle and side entry doors to the sanctuary, are propped open and will remain open for the entire worship service. (minimizes contact with the door handles and increases ventilation within the church building.)
- Bottles of liquid hand sanitizer will be available for use in the narthex, and you are encouraged as well to bring your own personal hand sanitizer. The water fountains outside the restrooms will be unplugged and covered on Sunday morning. Please bring your own personal water containers or bottles. No food or beverages will be offered. The sacristy room will be closed.
- When utilizing the restroom on Sunday morning, note whether another person is already using the room, and wait outside until that person exits the restroom before entering. Wash your hands thoroughly with soap and water prior to exiting the restroom.
- While inside the church building, **we are strongly encouraging that each person wear a face covering or mask.** A limited number of surgical masks will be available if you forget your own personal face covering.
- If on Sunday morning you are experiencing a fever (in excess of 100.4° F), coughing, shortness of breath or other symptoms potentially indicating COVID-19 infection, please refrain from attending worship on that morning and seek medical assistance.

The worship service itself will, not surprisingly, be a little different than what we are accustomed to. Some of the worship service modifications will be:

- We anticipate that attendance at the initial services will be quite modest, so the ushers should easily be able to assist individuals and family groups to find seating in the pews with appropriate social distancing.
- No printed bulletins will be distributed by the ushers. Everyone will receive an electronic version of each week's bulletin by email, and you are encouraged to print out the bulletin at home and bring it with you on Sunday morning. A limited number of printed bulletins will be available in the narthex. The bulletin will include the hymn lyrics.
- Hymnbooks, Bibles, pencils and attendance pads will be removed. Prayer request forms will be displayed on a table in the narthex, that can be filled out prior to the service, which can then be deposited in offering baskets located at the sanctuary entry doors.
- There will be no choir performances, and congregational singing of the hymns will be discouraged. Singing of the hymns in our minds, or possibly light humming, will be our means of expressing our musical worship.
- There will be no children's sermon or children's Sunday school classes, so children will remain with their families during worship. **No nursery attendants will be provided**, so use of the nursery room will be limited to parents and their children, if necessary.
- There will be no collection of offering during the service. Offerings will be deposited in the offering baskets located at the sanctuary entry doors when departing the sanctuary at the conclusion of the service.
- On Communion Sundays (e.g., June 7) servers will not be distributing the communion elements. Trinity has purchased a supply of prepackaged communion "sets", each with wafer and sealed juice cup, which will be placed on a table at the front of the sanctuary, to be picked up by individual worshippers at the appointed time during the communion service.
- Following Rev. Dunlap's benediction, he, or the preacher of the day, will immediately proceed outside the church building, to greet and chat with the worshippers in the safer, fresher outdoor environ (no rain please!). All of the attendees will be encouraged to proceed to the outside as quickly as possible. It's outside, in the fresh air, that we can really practice being the Trinity community of faith - socially distanced hugs, catching up on all our quarantine stories, etc.!

New Prayer Wall

Trinity has an exciting new capability through the website that allows anyone to post needed prayers on what we've called the "Prayer Wall". From the website home page, you may click on the Prayer Request image or click on the link:

<https://www.trinitypresbyfairfield.org/prayer-wall/>.

From there you may click on the button "Share your prayer request". Enter the information on the box that appears. You have the option to select whether you want the prayer: Shared online; Online but Anonymous; or Not shared online at all (in that case, the prayer is only sent to the church office and added to the traditional prayer list). You may also select the check box that will Email you when someone prays for your request. When you're finished making your selections, click the "I'm not a robot" box, and hit the submit button. That's it! We hope this new website feature is a blessing to Trinity.

Here is what the Prayer Wall looks like:

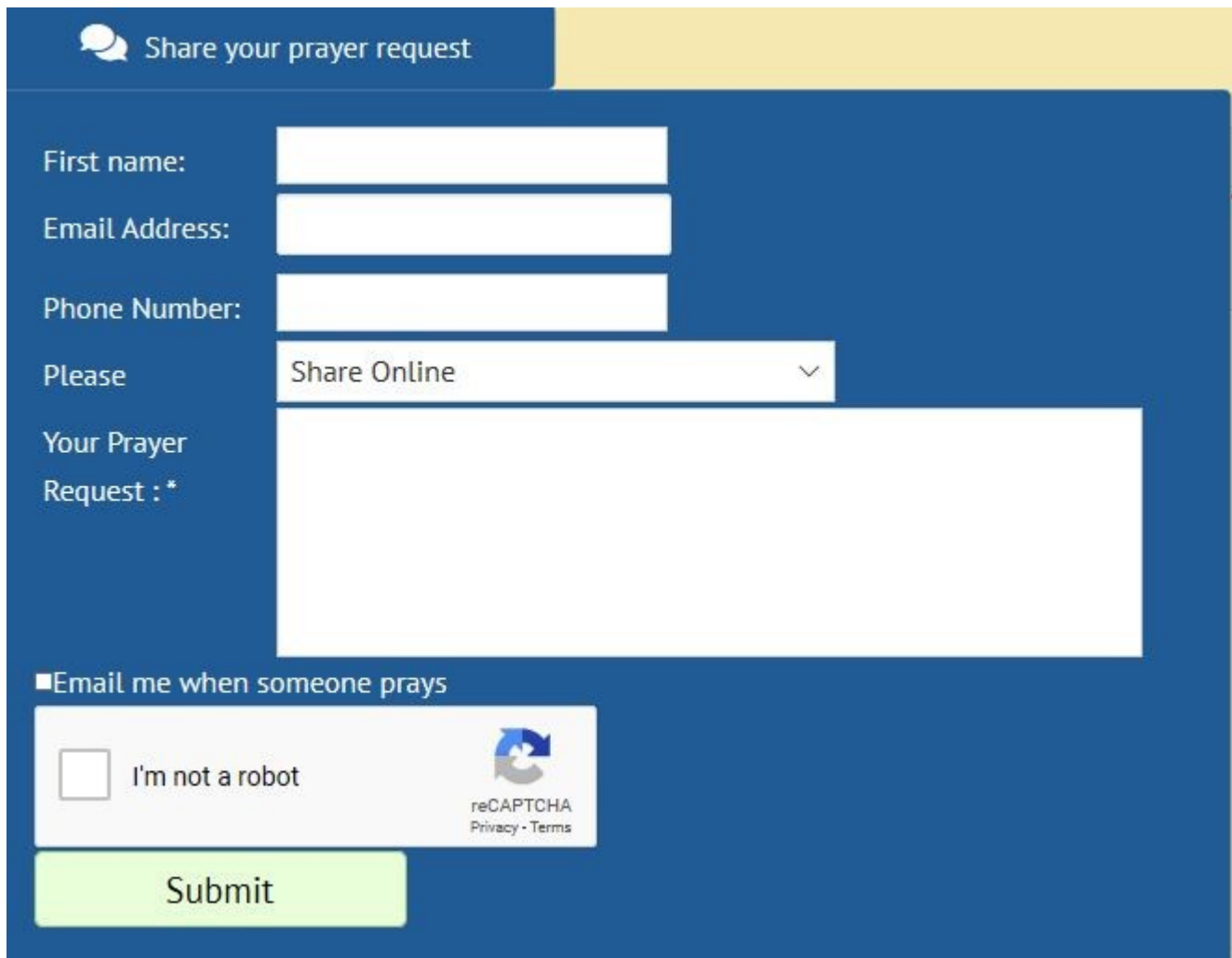

The screenshot shows a web form titled "Share your prayer request" with a blue header and a yellow background. The form fields are as follows:

- First name:** A white text input field.
- Email Address:** A white text input field.
- Phone Number:** A white text input field.
- Please:** A dropdown menu with "Share Online" selected and a downward arrow.
- Your Prayer Request : *** A large white text area for entering the prayer request.
- Email me when someone prays**
- I'm not a robot** (reCAPTCHA widget)
- Submit** (A green button)

At the bottom right of the reCAPTCHA widget, there is a logo and the text "reCAPTCHA Privacy - Terms".

New Life in Christ

Scripture: 1 Peter 2:2-10

Always Growing

Like newborn infants, long for the pure, spiritual milk, so that by it you may grow into salvation.

1 Peter 2:2

When the author of 1 Peter speaks to his readers about the Christian life, he chooses two utterly dissimilar images—growing infants and building a temple. Different as they are, these images have one thing in common. They both suggest a process that unfolds over time. Infants grow slowly into adults; temples take decades to build. Just so is the Christian life. We are always growing, or being built, into the men and women God is calling us to be. But the process takes time.

The Protestant reformer Martin Luther put it this way: “This life therefore is not righteousness, but growth in righteousness, not health, but healing, not being but becoming, not rest but exercise. We are not yet what we shall be, but we are growing toward it, the process is not yet finished, but it is going on, this is not the end, but it is the road.”*

Grow us, build us, a day at a time, into the men and women you call us to be. Amen.

Michael L. Lindvall, Fort Wayne, Indiana

*Martin Luther, “Defense of All the Articles,” Lazareth trans., quoted in Roy Moran, *Spent Matches: Igniting the Signal Fire for the Spiritually Dissatisfied* (Nashville: Thomas Nelson, 2015), 170.



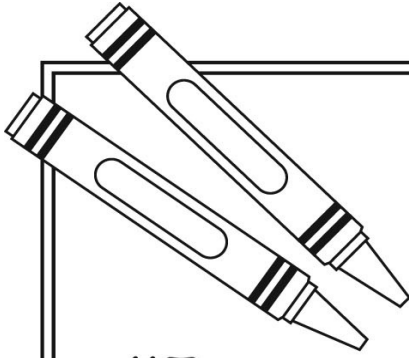

Just for **KIDS**

“I am with you always.”

Before Jesus ascended into heaven, he encouraged his disciples in the work they had to do. We, too, are Jesus' disciples and should follow his same instructions.



Follow the words in the clouds to find Mark 16:15-16a, NIV.

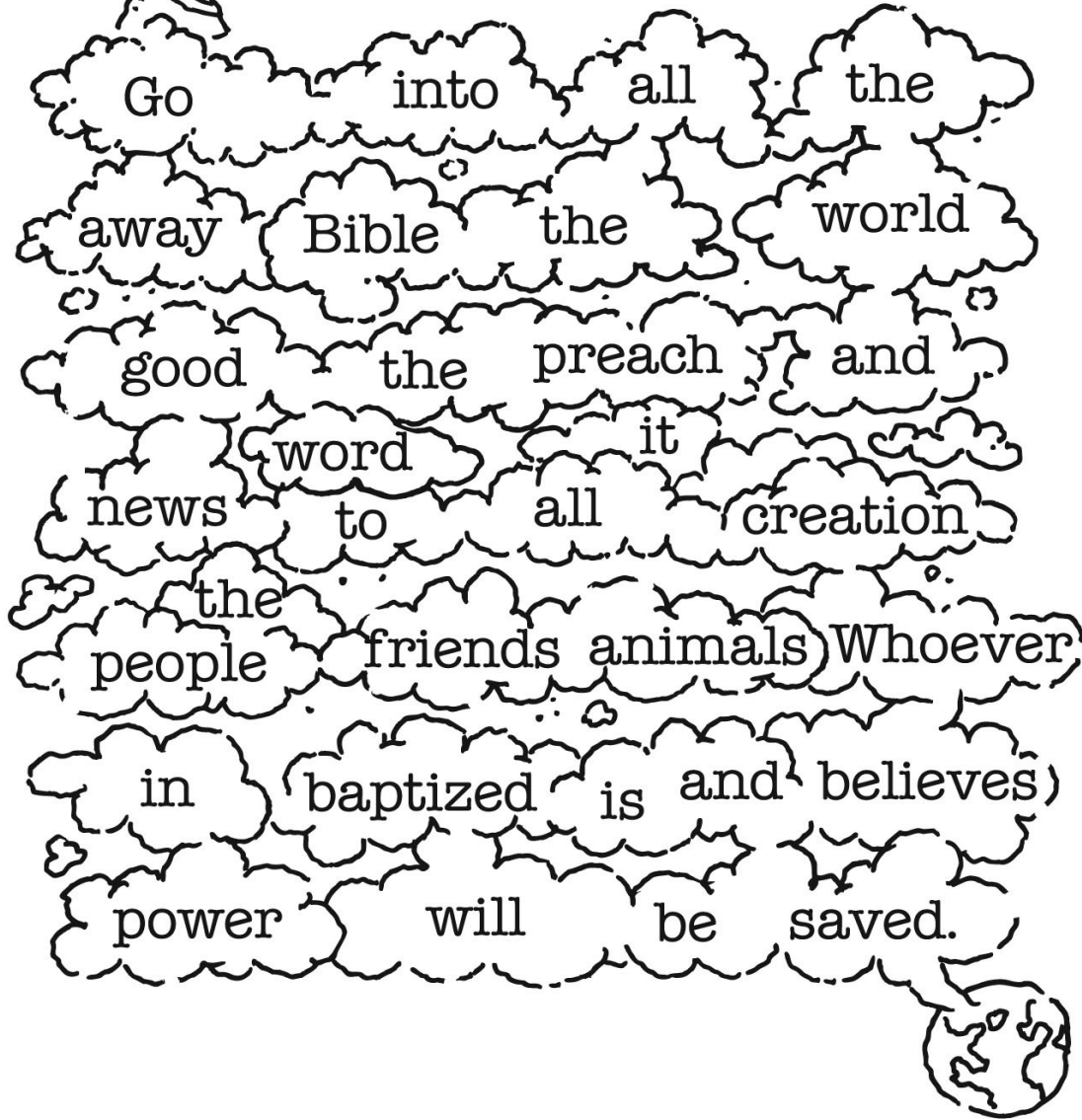

Answer: “Go into all the world and preach the good news to all creation. Whoever believes and is baptized will be saved.” (Mark 16:15-16a, NIV)

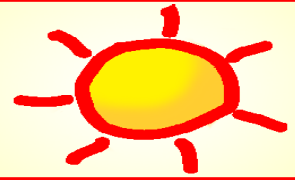

The Holy Spirit Comes

The apostles were together when suddenly a noise like a wind came into the house.

Connect the dots.
A B C D E F G H I J K L 1 2 3 4 5 6 7 8 9 10 11



• Children's Worship Bulletin™ •

Ages 7+

June 9, 2019 • Acts 2:1-21

The Holy Spirit Comes

Jesus' disciples were all together when a sound like wind filled the house and they saw what looked like tongues of fire over each of them.

Find 10 differences between the pictures below.

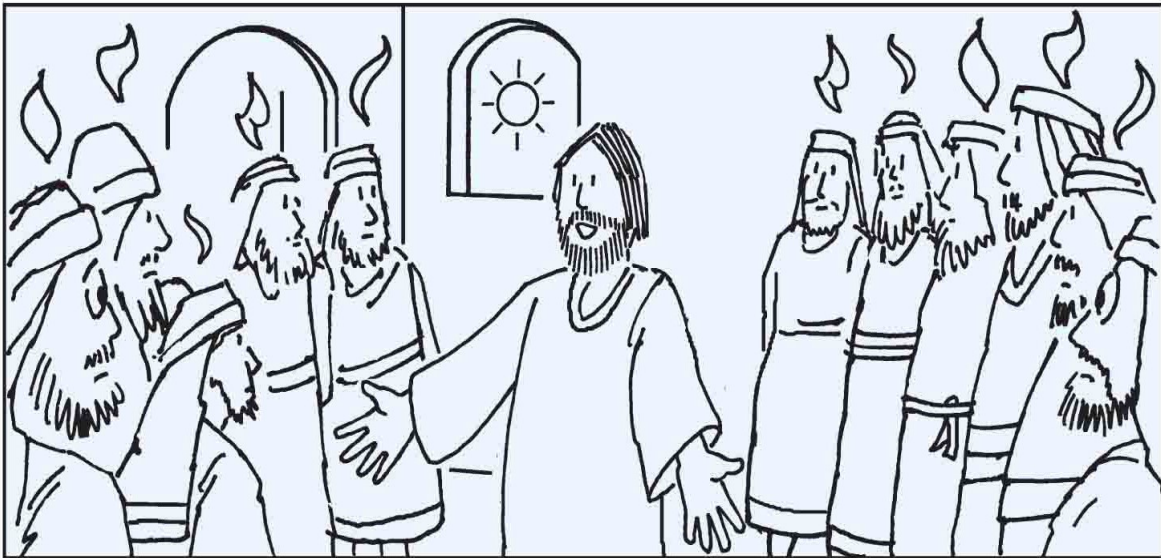

As of May 24

Keep in your Prayers

Gina Anaple	Healing/recovering surgery
Laverne Mitchell, Connie Williams req.	Healing/diagnosed advanced cancer
Chris Clark, Marta Mojzer's cousin	Healing/cancer has returned
Sandy Thien, Ginny Kramer's niece	Healing/cancer/chemo treatments beginning
Pam Kelso, Carol Kiphart's daughter	Healing/diagnosed with cancer
*Megan, Nadine Jones' granddaughter	God's Providence and care/mother of twins needs bone marrow transplant
*Donna Weber and family, Connie Williams req.	Bereavement loss of her husband
*Blake Tanner's family, Connie Williams req.	Bereavement loss to Blake
*Doug Conway, Harring request	Bereavement/loss of his son, a young military pilot
Fran Thomas	Healing/pain relief
Natasha, B. Pratt request	Healing/recovery surgery on legs
Jean Parsley	Continued healing
Pam Harring	Continued healing/guidance with treatment
George Liles	Continued healing/home recovering
Dee Burkhardt	Continued healing
Diane Niehaus, B. Luebbe request	Continued healing/several health concerns
Gerald Reese, M. Reese's father	Continued healing/swallowing problems
Margie, Fran Thomas' sister	God's peace and comfort
All peoples in the Middle East	Peace and reconciliation
All Elected Government leaders	Wisdom/support/enlightenment
Support for all our military	Strength/discernment/God's protection
For all missionaries (Especially for S. and B.)	Protection/blessings/fruitful mission work

Names that have been on the Prayer List for more than 4 weeks are marked with an asterisk (). If you would like them to remain on the list, please contact the office by Tuesday.*

Financial Information

Donations Received as of 5/3	\$2,395
Per Capita 2020 Donations	\$759
Property Fund Giving 2020	\$3,500
Property Fund Goal 2020	\$5,000

Per Capita for 2020 is \$33

Worship Schedule

May 31	Rev. Tom Dunlap
June 7	Rev. Tom Dunlap
June 14	Elder Kurt Schuler
June 21	Rev. Tom Dunlap
June 28	Elder George Fraley