



March 30, 2020

The Good News from Trinity PC

**Church Worship Services
and Activities are cancelled
for April 5.**

**Watch the newsletter for when
they will resume.**

**Office Open
9:00-Noon Monday-Thursday**

**Prayer Requests can be emailed to:
office@trinitypresbyfairfield.org**

Close at Heart

No distant Lord have I,
loving afar to be;
Made flesh for me, he cannot rest until
he rests in me.

Brother in joy and pain, bone of my
bone was he;
More intimate and closer still –
he dwells himself in me.

I need not journey far,
this dearest Friend to see;
Companionship is always mine; he
makes his home with me.
—Maltbie Babcock

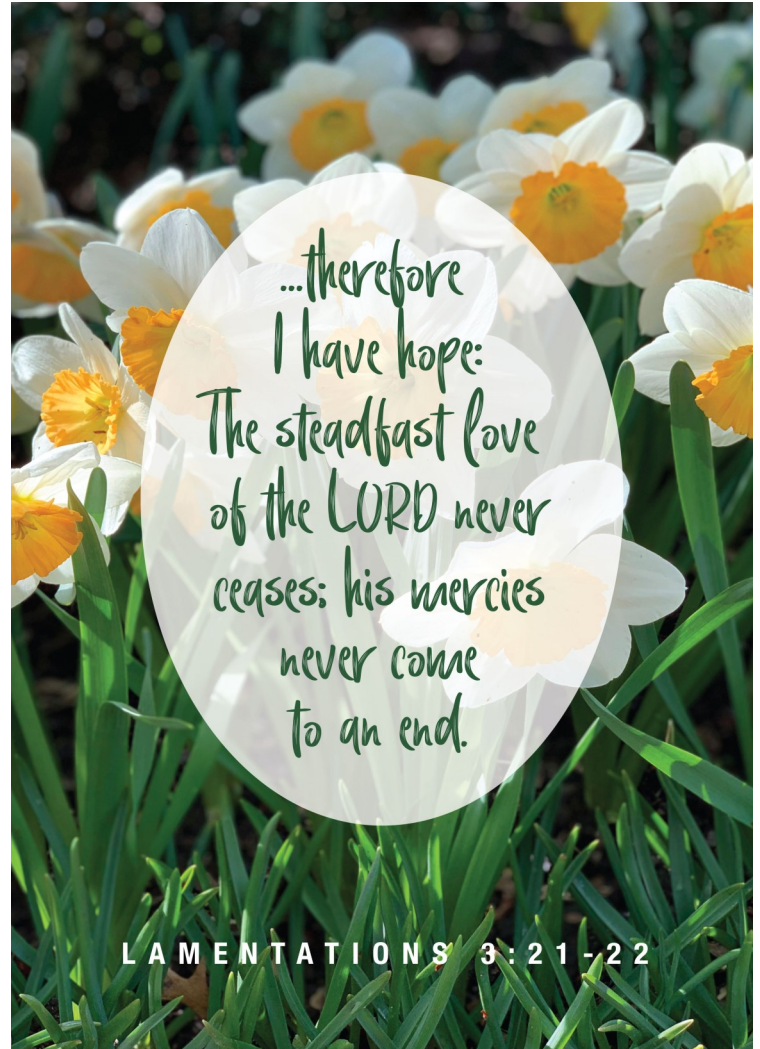

*...therefore
I have hope:
The steadfast love
of the LORD never
ceases; his mercies
never come
to an end.*

L A M E N T A T I O N S 3 : 2 1 - 2 2

**We thank, Worship Leaders for their
service:**

**All Worship Volunteer Leaders please watch
future Newsletters to know when the
Worship Schedule will resume.**



Trinity Presbyterian Church

Rev. Tom Dunlap Pastor

6081 Ross Road
Corner of Ross and Mack Roads
Fairfield, Ohio 45014

Phone: 513-860-4114
www.trinitypresbyfairfield.org E-mail:
office@trinitypresbyfairfield.org

Prepare for Worship Palm Sunday

Psalm 31:9-16

⁹ Be gracious to me, O LORD, for I am in distress;
my eye wastes away from grief,
my soul and body also.

¹⁰ For my life is spent with sorrow,
and my years with sighing;
my strength fails because of my misery,^[a]
and my bones waste away.

¹¹ I am the scorn of all my adversaries,
a horror^[b] to my neighbors,
an object of dread to my acquaintances;
those who see me in the street flee from me.

¹² I have passed out of mind like one who is dead;
I have become like a broken vessel.

¹³ For I hear the whispering of many—
terror all around!—
as they scheme together against me,
as they plot to take my life.

¹⁴ But I trust in you, O LORD;
I say, “You are my God.”

¹⁵ My times are in your hand;
deliver me from the hand of my enemies and per-
secutors.

¹⁶ Let your face shine upon your servant;
save me in your steadfast love.

Reflection

As this week unfolds, spend some time each day pondering the mind of Christ. What is the shape of his compassion? Describe the image of such great love. Finally, what does it feel like, physically, to be so utterly cared for?

Morning Prayer

I rise, O God, awakened by your Word, to live another day. Lead me in your path. Show me the steps to take toward greater faith. Hold me in your care as I move through this Holy Week where the shadows deepen even in the daylight. Hosanna! Save me now, dear God! Amen.

—adapted from *Feasting on the Word Worship Companion: Liturgies for Year A, Volume 1* © 2013 Westminster John Knox Press



A prayer for Our Times

O God, we pray for a broader vision of the needs of humanity, and a deeper compassion to fill those needs; for a planting of the seeds of concern for all humanity in our hearts; for a tapping of the wells of generosity. May we live together as people who have been forgiven a great debt. May we be gentle, walking softly with one another. May we be understanding, lest we shall add to the world's sorrow or cause to flow needless tears. May we be as anxious for the rights of others as we are for our own. May we be as eager to forgive as we are to seek forgiveness. May we know no barriers of creed or race or sex, that our love may be like Yours — a love that sees all people as Your children and our kin. May we be ministers of humanity.

—Peter Marshall

Rev. Dunlap's Sermons on-line

Pastor Tom Dunlap has recorded his message for this week. Click on the link below to the our website and listen to his message to the people of Trinity. To hear, simply click on the play button on the March 28, 2020 player on the webpage to hear God's word for the week. You may also click on the PDF next to the player to read along.

<http://www.trinitypresbyfairfield.org/march-2020.html>

Deacons, please pass on the email link to everyone in your care groups.

Easter Brunch

The Fellowship Committee has reached the decision to not have Easter Brunch this year.

Lenten Mission Project

The Lenten "bag" collection of items for the food pantry and the non-food pantry can be dropped off at the church Monday through Thursday from 9:00-noon.

Missions at Work

- ♦ Sewing of dresses for Mission Project in Appalachia will be held the 2nd Tuesday of the month at 10:00 AM
- ♦ Knitters /Crocheters: Mercy and our church are in need of prayer shawls and baby blankets.
- ♦ NON food Pantry needs: shampoo and dish soap for February.
- ♦ Collecting plastic lids, soda pull tabs, and cancelled stamps

Palm Sunday

As we reflect on Palm Sunday, from our many locations we can be thankful that Trinity and over a 1,000 other congregations supported Eco-Palms. The *Eco-Palm Project* provides an opportunity to purchase high quality *Chamaedorea* palm fronds— a purchase which supports indigenous communities in Guatemala and Mexico, as well as preserves the rainforest. The Eco-Palms concept teaches villagers sustainable harvesting techniques; eliminates middlemen; pays more for harvesting.

Though it seems like a small project, use of the Eco-Palms means that an increase of 250% of the money from the palms is going directly back into the harvesting communities.



One Great Hour—April 12 and April 19

Where God is, there is hope for the suffering and the vulnerable.

Each gift to One Great Hour of Sharing helps to improve the lives of the suffering and the vulnerable. Providing relief from natural disasters, food for the hungry, and support for the poor and oppressed.

Together, we become the household of God. We extend shelter to those who have no place to stay, offer compassion to those who have pain—be it physical, emotional or spiritual—and we set a feast, with God, for those who lack access to enough food to eat. Due to the cancellations of our worship services, *the One Great Hour of Sharing will be received on Sundays, April 12 and April 19. Instead of having individual collections for the different disasters, this Disaster Offering will be including funds for all future disasters.*

Uplifting Sources

There are a myriad of online devotions available as well.

"Devotions on the go - www.d365.org" This is a free online daily devotional provided by the Presbyterian Church (U.S.A) and an app is available for cell phones.

"Dial Hope"- An alternative to the digital world and online. You can listen to a brief message and prayer by calling 866-528-4673. Also available online www.dialhope.org The messages are prepared and read by Joe Albright, a Presbyterian pastor from Florida.

"Our Daily Bread" - www.odb.org - Daily devotions free online. —Lisa Allgood, *Cincinnati Presbyterian*

PASTORAL LETTER

I hope this finds all of you well and remaining patient. The likely date when we will be able to reconvene for worship is being pushed back again and again. While there is nothing definitive Yet, Ohio isn't supposed to peak until mid May. The Presbytery advisory last week indicated it might not be safe to have gatherings again until late April. So I am guessing—**guessing**—that it will probably—**probably**—maybe—**maybe** be the first Sunday in May.

What this means is that we are dealing with one of the most common themes in all of religious experience—waiting. The Jews have been waiting for the Messiah for about 5000 years. The first followers of Jesus were waiting for the Second Coming. And we are waiting for life to resume to normal. But waiting does not mean giving up. In fact, how we wait is an important spiritual activity. Because what waiting invites us to do is live in the present moment. For isn't it true that the present is really the only place we can be anyway? Impatience about the future coming only leads to anxiety or depression or anger. And those emotions only make the present pretty miserable.

So here is what I suggest. Accept the slower pace of life you are now living. Take time to just BE. Enjoy the flowers and the budding trees and the brilliance of the greening grass. And fill your days with as many Thank You breaths as you can remember to take. Paying attention to your breath is the most effective way to reconnect you to your present when you have gone off to future or past land. And let us continually recall the scripture: *Be still and know that I am God.*

The future will come and then it will be the present.

Blessings and Peace...Tom

Puzzle!

Find and circle these words associated with the Lenten journey to the cross.

colt
confess
cross
crown
crucifixion
death

denial
donkey
forsaken
Gethsemane
Golgotha
hosanna

kiss
lots
palms
penance
Pilate
prayer

repent
silver
sins
suffer
thorns
vigil

E N A M E S H T E G R L W Y
C L E U X B M T H B U C W B
N R I K Y P A T E T I Y X Y
A V J G A L B R E Y A R P B
N G N L I S N L A I N E D X
E W M P R V R D H B N R D F
P S O G O L G O T H A B S C
D L N R O C O N F E S S I K
O T H T C P E K W U O U N D
M N S H N P W E D R H F S K
U N F O E T K Y C S G F O E
H E C R E V L I S W Q E C M
H V H N C X S O C C J R L O
F Q E S U D S H C A A Y M C
C R U C I F I X I O N S R V

Just a little note to say hello!

And we know that for those who
love God all things work together
for good, for those who are called
according to his purpose.
Romans 8:28, ESV

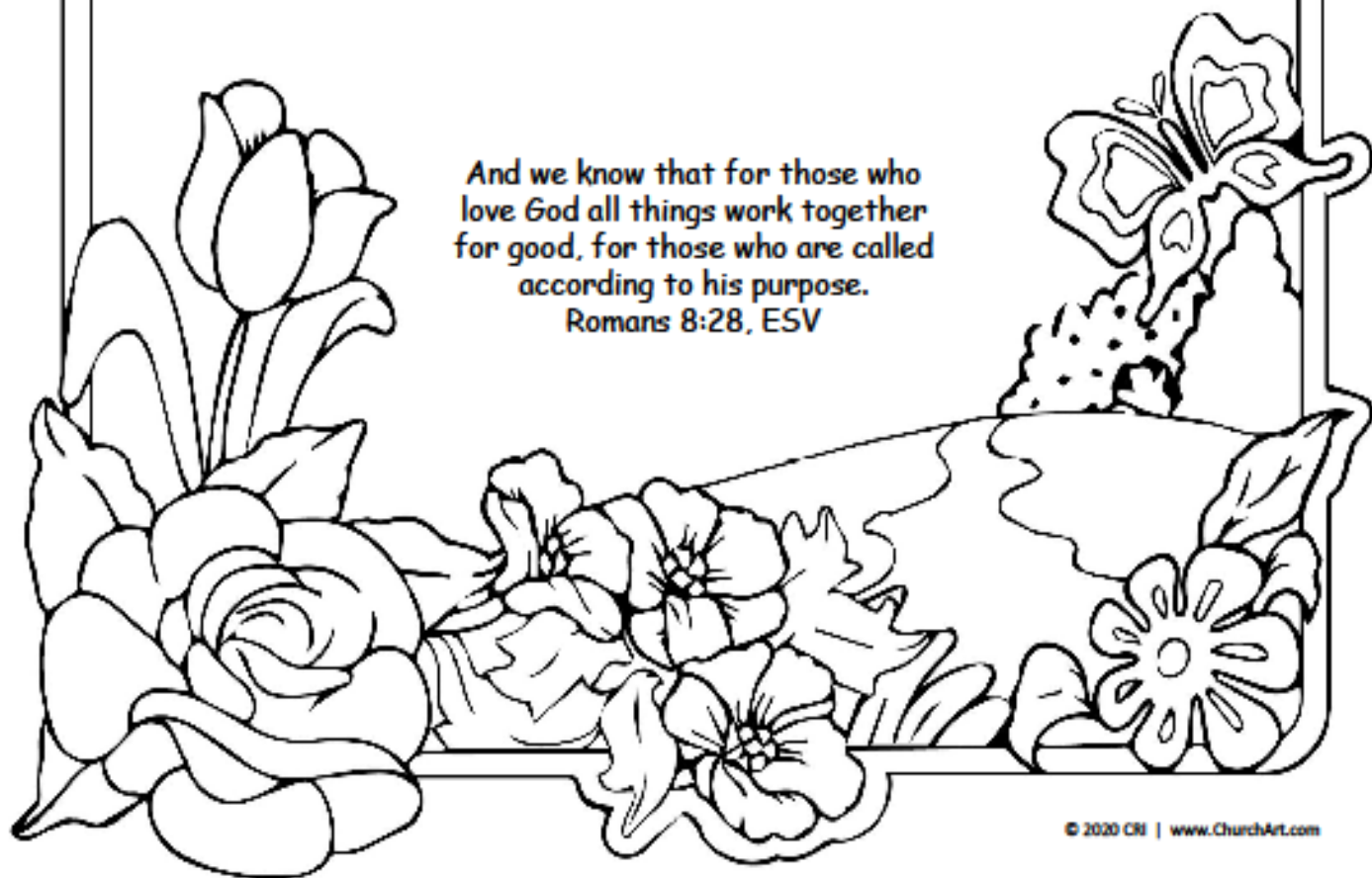

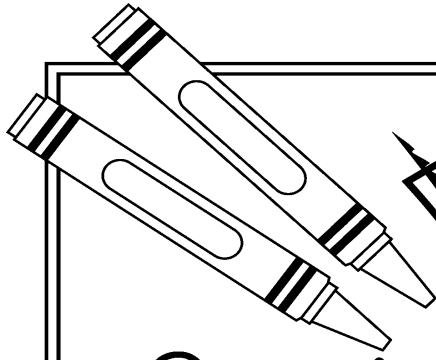





PUZZLE

Spring's Beauty

During springtime, the beauty of God's creation emerges in many ways.

Directions: Use the vowel code below to complete Psalm 8:1, NIV.

A =  E =  I =  O =  U = 

"L__RD, __ __ r L__rd, h __ w
m__ j __ st__ c __ s y __ __ r
n __ m __ __ n __ ll th __
__ __ rth!"

Ps __ lm 8:1, N __ V

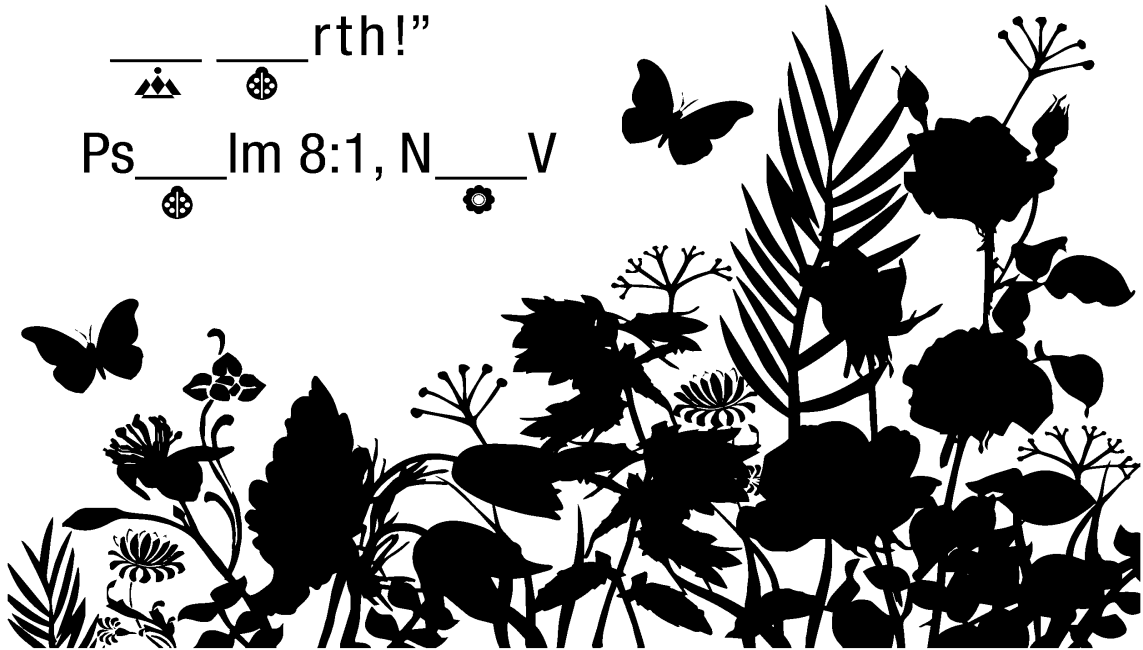

Answer: "LORD, our Lord, how majestic is your name in all the earth!"
Psalm 8:1, NIV



“Welcome aboard ‘Anointed Airlines,’ Pastors!
 What say we begin by testing your faith
 right away?! Please join us in celebrating
 our captain’s birthday...She’s 104 today!!”

- It is pleasing to the dear God whenever you rejoice or laugh from the bottom of your heart.
 –Martin Luther
- Our laughter here on Earth is but a tune-up for the joyful hallelujahs of being in God’s presence.
 –Terry Lindvall
- Memory feeds a culture, nourishes hope and makes a human, human.
 –Elie Wiesel

Love and Laughter Go Hand in Hand!

Humor can brighten a day!

Q: What valentine did the French chef give his wife?
 A: A hug and a quiche

Q: What did the paper clip say to the magnet?
 A: “I find you very attractive.”

Q: What did the pencil say to the paper?
 A: “I dot my i’s on you!”

Q: How did the phone propose to his girlfriend?
 A: He gave her a ring.

Q: What do you call a very small valentine?
 A: A valentiny



As of March 29

Keep in your Prayers

Jeff, Deb Schoenherr's son	For good test results from last week's biopsy
Sandy Thien, Ginny Kramer's niece	Healing/cancer/chemo treatments beginning
Springdale police officers, Fran Thomas	Bereavement for the loss of one officer;
	Healing for the injured second officer
Vicky Callow, Bill Tope's granddaughter	Thanksgiving for safe return to Muncie, IN from her mission trip to Colombia, S.A.
Pam Kelso, Carol Kiphart's daughter	Healing/diagnosed with cancer
Megan, Nadine Jones' granddaughter	God's Providence and care/mother of twins needs bone marrow transplant
Vickie Murrell, Harrings' request	Healing/recovering from heart surgery
People of Nashville	God's providence and comfort
Jack Kraft, K. Kessler request	Healing/severe leg infection
Caleb Erickson, D. Hess request	Continued healing/fighting infection
John Marshall, D. Hess request	Healing/dialysis and tumor concerns
Cassie, J. Reese request	Continued healing/improving/infections
Robbie, B. Pratt request	Healing/hearing threatening voices
Charlene Stumpf, K. Kessler request	Healing/knee surgery
*Nancy Miracle, Schuler request	Healing/in decline from ALS
*Billy, D. Hess request	Healing/heart surgery and mini stroke
Fran Thomas	Healing/pain relief
Natasha, B. Pratt request	Healing/recovery surgery on legs
Jean Parsley	Continued healing
Pam Harring	Continued healing/guidance with treatment
George Liles	Continued healing/home recovering
Dee Burkhardt	Continued healing
Diane Niehaus, B. Luebbe request	Continued healing/several health concerns
Gerald Reese, M. Reese's father	Continued healing/swallowing problems
Margie, Fran Thomas' sister	God's peace and comfort
All peoples in the Middle East	Peace and reconciliation
All Elected Government leaders	Wisdom/support/enlightenment
Support for all our military	Strength/discernment/God's protection
For all missionaries (Especially for S. and B.)	Protection/blessings/fruitful mission work

Names that have been on the Prayer List for more than 4 weeks are marked with an asterisk (). If you would like them to remain on the list, please contact the office by Tuesday.*

Financial Information

Donations Received as of 3/29	\$830
Kroger Rewards	\$55
Per Capita 2020 Donations	\$462
Property Fund Giving 2020	\$3,000
Property Fund Goal 2020	\$5,000

Per Capita for 2020 is \$33

Tentative Preaching Schedule

April 12	Rev. Tom Dunlap
April 19	Elder Kurt Schuler
April 26	Elder Cindie Postell